

ELASTEC

Duck Skimmer

Weir Skimmer for Ponds and Calm Waterways



Oil Spill Equipment | Floating Barriers | Incinerators



Elastec DUCK Skimmers are self-adjusting, floating weir skimmers that can be used for duckweed or water meal removal. They can also be used for oil spills.

The ELASTEC DUCK skimmer is a high capacity weir skimmer suited for inland waterways and ponds, the design incorporates a self-adjusting weir that pivots within a robust, lightweight floating frame. The suction connection is fitted with a standard Camlock coupling, to which a suitable suction pump or vacuum truck can be coupled. This skimmer automatically adjusts skimming volume according to flow created by the external pump (optional). The skimming depth can be increased with a higher flow rate. The high throughput help draw the algae over the weir, discharge from pumps can be filtered before returning water to source.



Duck 100

Weir skimmers operate by taking the surface layer of the water, material lows into the central hopper, drawn in by the water flow created by the external suction pump. Loose, floating material on the surface of the water (duckweed, algae, weeds, oil, water meal, scum) will be carried into the sump. The larger skimmer is fitted with boom connectors so that the material can be funneled to the inlet. (boom sold separately).

Available in two different sizes, depending on the size of the job and the flow rate needed to pull in material. The DUCK 50 is fitted with a 2 inch Camlock coupling, the DUCK 100 has a 4 inch. Our floating surface skimmers can skim large areas quickly and effectively. Elastec has been manufacturing skimming devices since 1990.

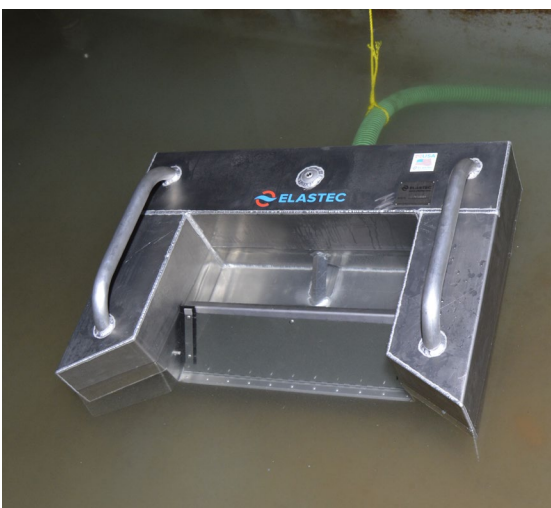

Duck 50

Contact us with your weed management issue and we can provide a solution that includes appropriate skimmer, and pump for the job.

Optional extra: Pump, hoses

Duck 100

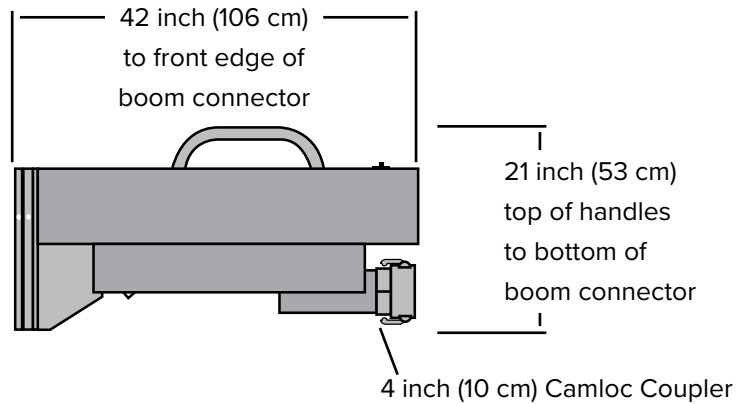
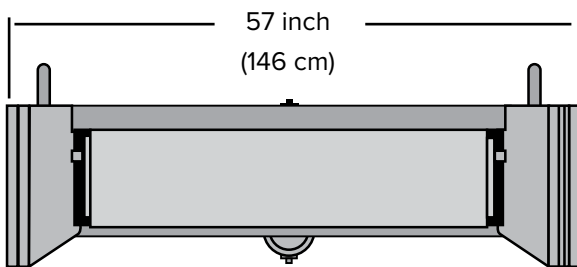
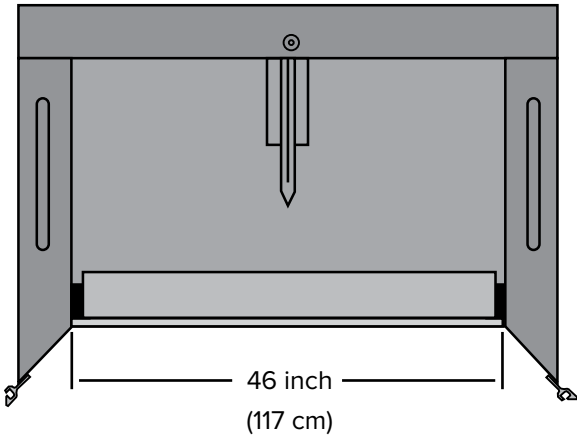

Specifications:

Weight:	70 lb / 31.75 kg
Dimensions:	57 x 42 x 21 inch / 146 x 106 x 43 cm
Capacity:	Variable but has been verified to function properly up to 650 gpm
Solids Handling:	Limited by pump
Suction:	4" screw on Camlock
Lifting Point:	Double handles
ASTM compliant boom connectors	

Duck 50

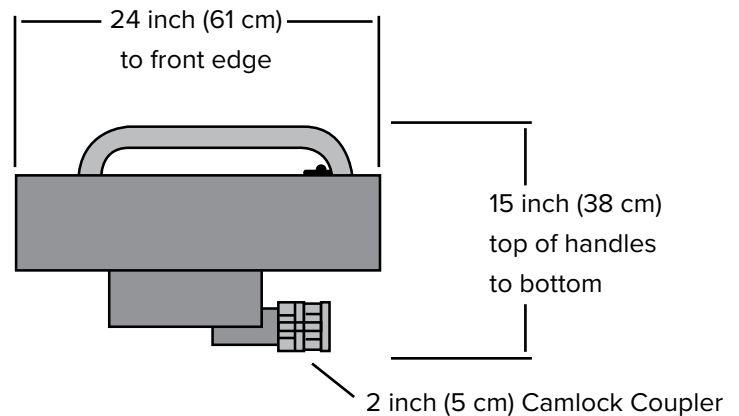
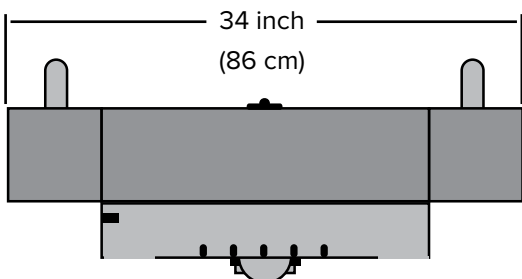
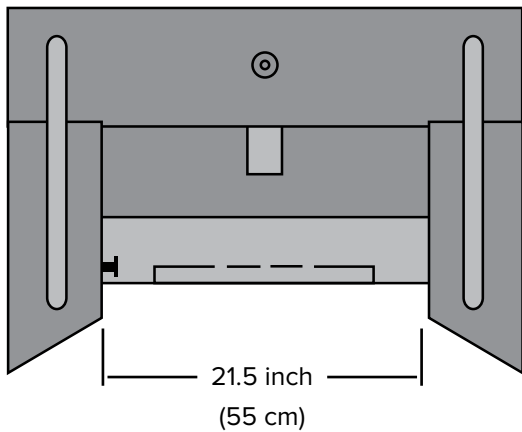

Specifications:

Weight:	23 lb / 10 kg
Dimensions:	34 x 24 x 15 inch / 86 x 61 x 38 cm
Capacity:	Varies based on pump or vacuum
Suction:	2" screw on Camlock
Lifting Point:	Double handles

Pump Options

Centrifugal Pump

A self-priming centrifugal pump powered by a 15 hp 208/230V 60 Hz 3-phase electric motor. The pump is housed in a steel frame with a lifting ring and comes with an electrical disconnect with circuit breaker and 25 ft of electrical cable. Self-priming to 20 feet after initial prime. Cast iron housing with SS impeller nitrile seal and o-ring. The pump also includes a 4" ball valve for regulating the flowrate. Also available in 460V / 10hp (lower flowrate) 208-230V/460V.



Specifications:

Maximum flow:	660 gpm / 149 cu.m/hr
Maximum head:	114 feet / 34.75 m
Solids handling:	0.5 inch / 12.7 mm, 4 inch / 101.6 mm NPT suction and discharge ports fitted with 4 inch / 101.6 mm camlock adapters
Dimensions:	31 x 38 x 34 in / 0.78 x 0.97 x 0.86 m
Weight:	404 lbs

E370 Centrifugal Trash Pump

The Elastec E370 is a high volume portable all purpose diesel driven trash pump suitable for a variety of applications - liquid transfer, flushing, dewatering etc. Fitted with a cast iron impeller to resist abrasion. It features one tool serviceability for easy clean out, aluminum housing, cast iron wearparts, built in check valve, suction strainer and painted heavy duty steel roll frame. 3 inch Camlock couplings.



Specifications:

Engine:	Yanmar L70 diesel engine, electric start, Tier 4
Pump:	Silicon carbide mechanical seal, integral EPDM/EPR check valve, anti vibration mounts
Capacity:	303 gpm / 69 cu.m/hr
Max Total Head:	Up to 89 ft / 27 m
Discharge and Suction:	3 inch / 80 mm Camlock Couplings
Max Solids Handling:	.83 inch / 21 mm
Self Priming:	Up to 23 ft / 7 m
Max Fluid Temp:	180 F / 82 C
Dimensions:	27 x 19 x 28 inches / 680 x 484 x 710 mm
Weight:	209 lbs / 95 kg
Optional:	Suction and discharge hose, spark arrestor, wheel kit

SHOREMAX Water Pump

The ShoreMax is a lightweight portable water pump. It consists of a 3.5 HP gasoline engine (EPA compliant) driving a pump made of lightweight corrosion resistant polypropylene components.

Specifications:

Engine:	3.5 HP gasoline engine
Capacity:	200 gpm / 45 cu.m/hr
Max Pressure:	55 psi / 3.8 bar
Max Priming Lift:	20 ft / 6 m
Discharge and Suction:	2 inch / 50 mm Camlock Couplings
Solids Handling:	3/8 inch / 9.5 mm
Dimensions:	23 x 16 x 16 inch / 0.58 x 0.40 x 0.40 m
Weight:	62 lb / 28 kg



1309 West Main St.
Carmi, Illinois 62821, USA
+1 (618) 382-2525
www.elastec.com elastec@elastec.com